

higher education & training

Department:
Higher Education and Training
REPUBLIC OF SOUTH AFRICA

T1150(E)(A4)T

NATIONAL CERTIFICATE

MECHANOTECHNOLOGY N3

(8190373)

4 April 2017 (X-Paper)

09:00–12:00

Calculators may be used.

This question paper consists of 10 pages, 1 formula sheet and 2 tables.

DEPARTMENT OF HIGHER EDUCATION AND TRAINING
REPUBLIC OF SOUTH AFRICA
NATIONAL CERTIFICATE
MECHANOTECHNOLOGY N3
TIME: 3 HOURS
MARKS: 100

INSTRUCTIONS AND INFORMATION

1. Answer ALL the questions.
 2. Read ALL the questions carefully.
 3. Number the answers according to the numbering system used in this question paper.
 4. Keep questions and subsections of questions together.
 5. Write neatly and legibly.
-

QUESTION 1: POWER TRANSMISSIONS

- 1.1 A 16 N SPB wedge belt is installed between a compressor and a 15 kW electric motor with a speed ratio of 1,79 : 1. The speed of the pulley on the compressor is 700 r/min and that of the electric motor is 1 440 r/min. The approximate centre distance between the drives is ± 767 mm. The service factor is 1 : 1.

Refer to the attached TABLE 1 and TABLE 2 and use the following information to partially design the belt drive:

- 1.1.1 Determine the correction factor (1)
- 1.1.2 Calculate the design power (1)
- 1.1.3 Determine the pitch diameter of both pulleys (2)
- 1.1.4 Calculate the belt length (3)

Refer to FIGURE 1 below and label the cross-sectional views of the component as indicated. Write only the part next to the letter (A–E) in the ANSWER BOOK.

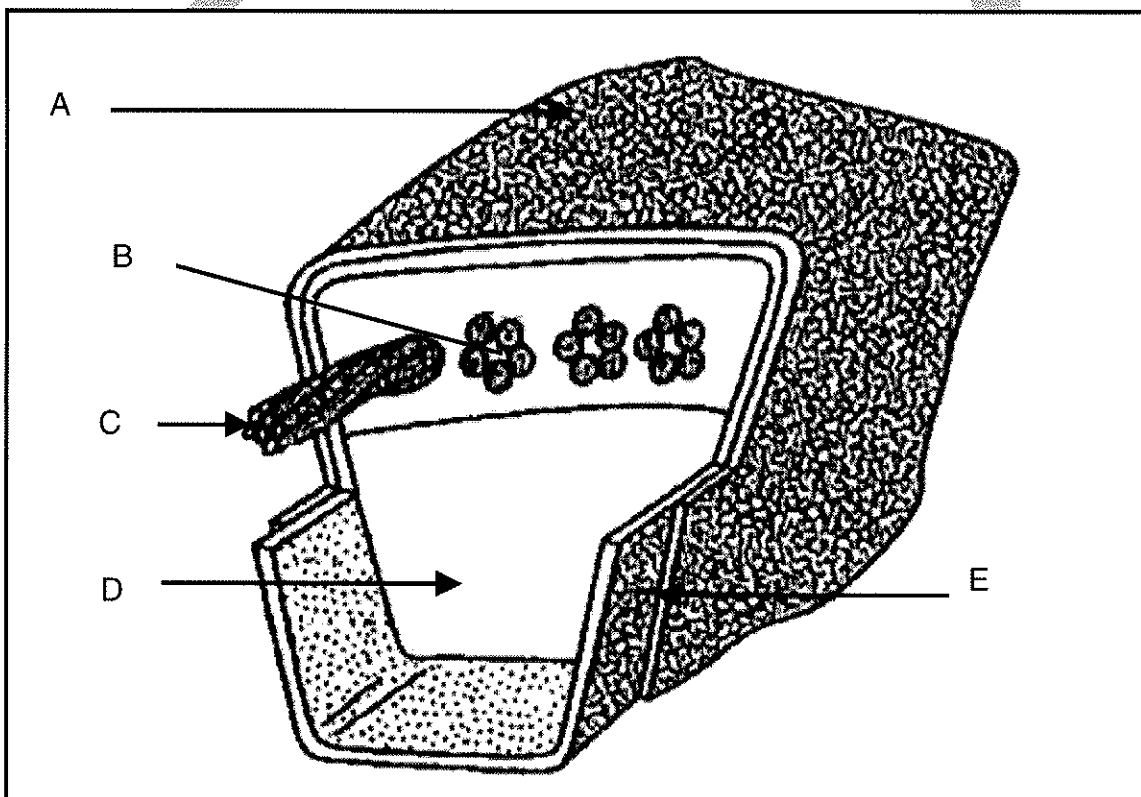

FIGURE 1

(5 × 1)

(5)

- 1.3 Refer to FIGURE 2 and label the clutch parts as indicated. Write only the part next to the letter (A–G) in the ANSWER BOOK.

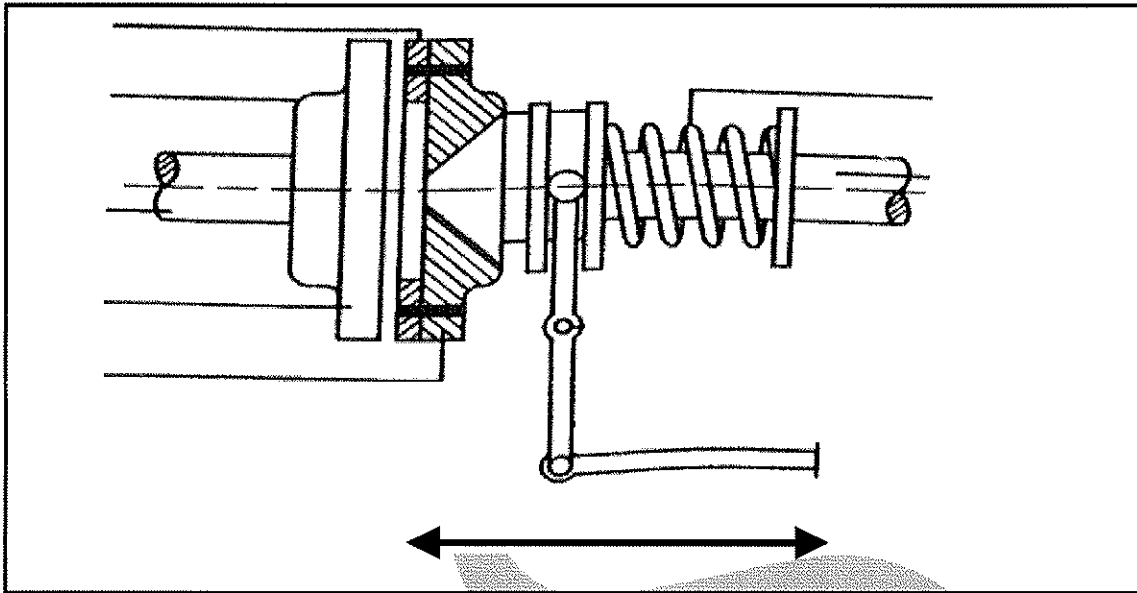

FIGURE 2

(7 × 1)

(7)

- 1.4 Indicate if the following statement is TRUE or FALSE. Choose the answer and write only 'true' or 'false' next to the question number (1.4) in the ANSWER BOOK.

A spiral claw clutch can be used to transmit energy from one shaft to another. This can be in both directions of rotation.

(1)
[20]

QUESTION 2: BRAKES

Refer to FIGURE 3 below of an electromagnetic brake and label the parts (A–E) in the ANSWER BOOK.

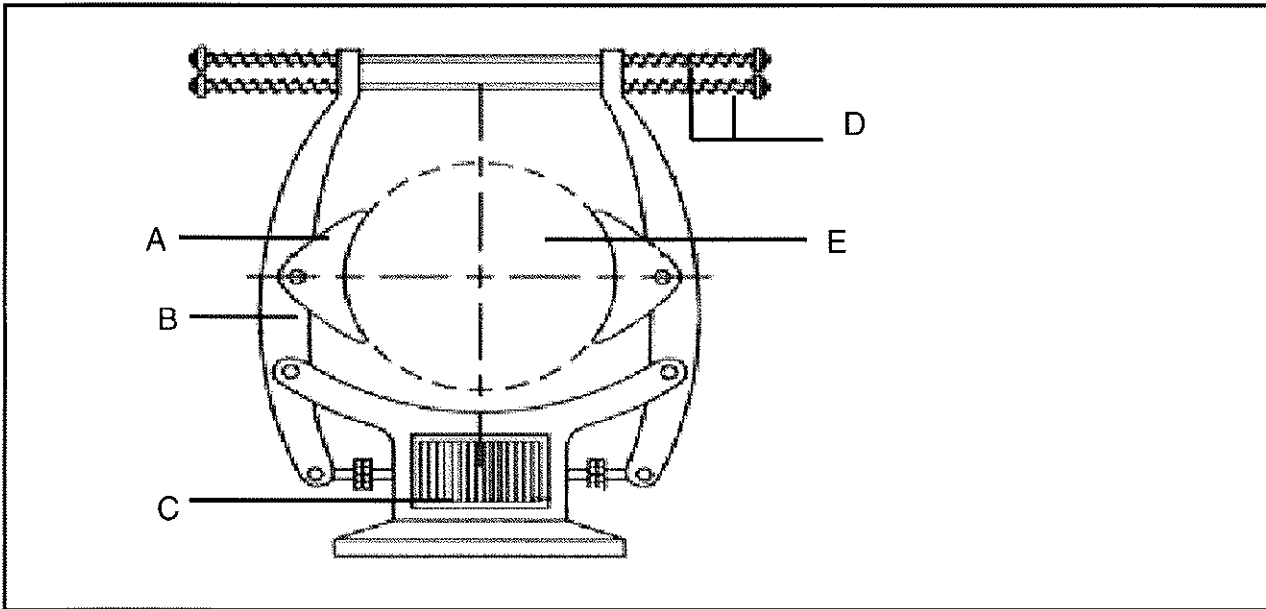
**FIGURE 3**

(5 × 1)

[5]**QUESTION 3: BEARINGS**

3.1 Refer to TABLE 2 below and determine the following:

- 3.1.1 The nominal outside diameter of bearing 626
- 3.1.2 The nominal width of bearing 623
- 3.1.3 The nominal bore diameter of bearing 626
- 3.1.4 Basic dynamic load rating of bearing 629
- 3.1.5 Basic static load rating of bearing 604

(5 × 1)

(5)

Principal dimensions			Basic load ratings		Bearing number
d mm	D mm	B mm	Dynamic N	Static N	
3	10	4	488	146	623
4	12	4	806	280	604
6	19	6	1 720	620	626
9	26	8	4 620	1 960	629

TABLE 2

3.2 Refer to FIGURE 4 of an anti-friction bearing and label the parts (A–E).

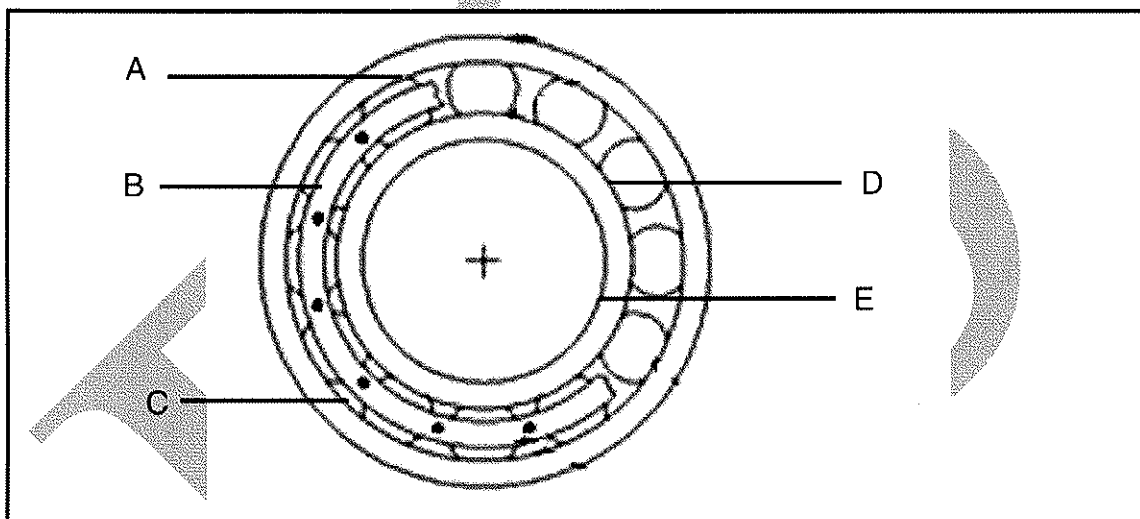

FIGURE 4

(5 × 1)

(5)
[10]

QUESTION 4: WATER PUMPS, COOLING AND LUBRICATION

- 4.1 Define *lubrication*. (2)
- 4.2 List FOUR negative results when too much oil is added as a lubricant to the mixture of fuel and air in two-stroke petrol engines. (4)
- 4.3 State THREE advantages of the impeller-assisted cooling system. (3)
- 4.4 FIGURE 5 shows three main types of impellers used on centrifugal pumps. Name each impeller by writing only the answer next to the letter (A–C) in the ANSWER BOOK.

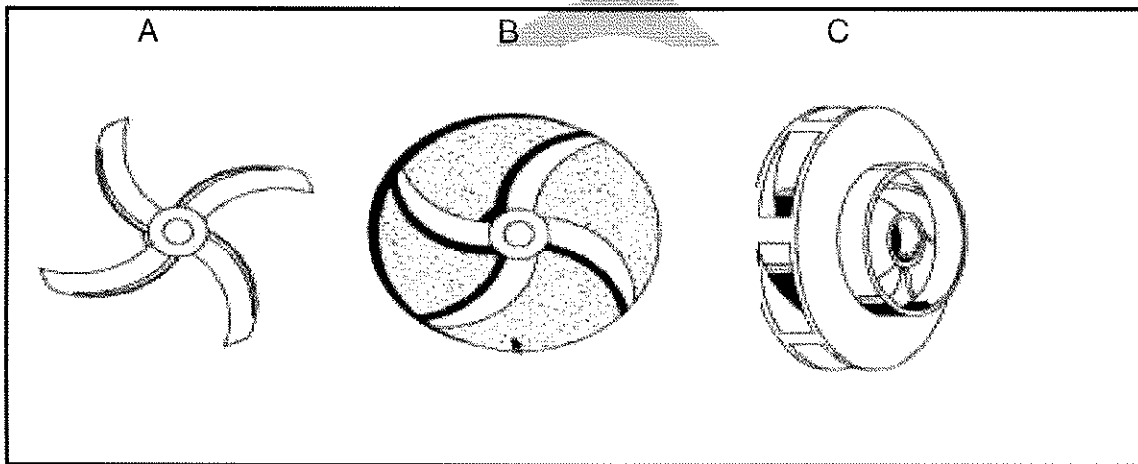

FIGURE 5

- 4.5 Name the THREE main moving elements of a reciprocating pump. (3)
- [15]

QUESTION 5: HYDRAULICS AND PNEUMATICS

- 5.1 The diameter of a plunger in a hydraulic cylinder is 45 mm and the length of the cylinder is 120 mm. During operation a pressure of 340 kPa is exerted on the plunger.

Calculate the following:

- 5.1.1 The cross-sectional area of the plunger (answer in m^2) (2)
- 5.1.2 The force on the plunger (answer in newton) (2)
- 5.1.3 The work done by the plunger, if the plunger moved a distance of 80 mm (answer in joules) (1)
- 5.2 Draw a neat labelled sketch of a weight loaded accumulator showing the following:
Weight, plunger, cylinder, inlet and outlet of the fluid. (5)

[10]

QUESTION 6: INTERNAL COMBUSTION ENGINES

- 6.1 State the function of the following components of a fuel system:

6.1.1 Float

6.1.2 Venturi

6.1.3 Fuel-level sending unit

(3 × 1) (3)

- 6.2 Define the *compression ratio* of an internal combustion engine. (2)

[5]

QUESTION 7: CRANES AND LIFTING MACHINES

7.1 FIGURE 7 shows a multi-part reeling system. Label the parts (A–D).

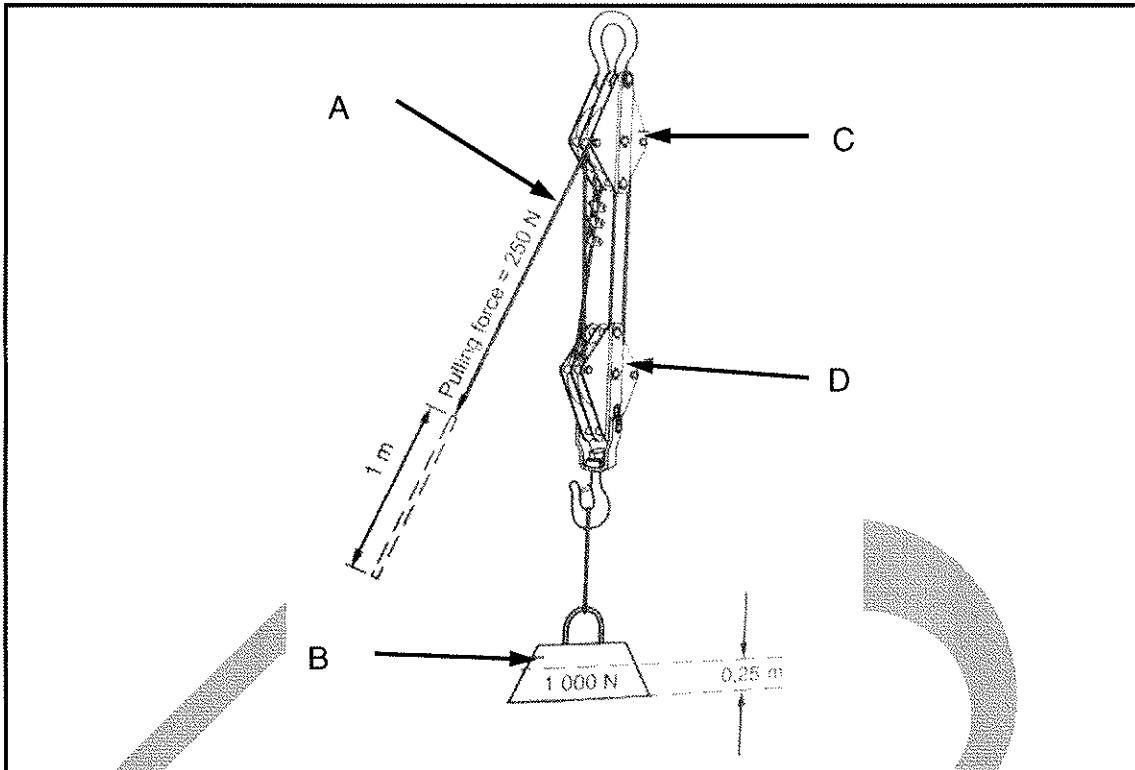

FIGURE 6

(4 × 1) (4)

7.2 State FOUR factors to be considered to construct a crane as strongly and economically as possible.

(4)
[8]

QUESTION 8: MATERIAL AND MATERIAL PROCESSES

8.1 State THREE purposes why you need a hardening process on steel.

(3)

8.2 List TWO main groups of plastic materials.

(2)

8.3 State the basic characteristics from non-laboratory tests with reference to the hardness of the following:

8.3.1 Polystyrene

8.3.2 Polypropylene

(2 × 1) (2)
[7]

QUESTION 9: INDUSTRIAL ORGANISATION AND PLANNING

- 9.1 State FOUR purposes of requisitioning with regard to the ordering of goods in an organisation. (4)
- 9.2 State FOUR benefits of a well-planned budget for a company. (4)
- 9.3 State the purpose of keeping to maintenance schedules on machines. (4)
- [12]**

QUESTION 10: ENTREPRENEURSHIP

- 10.1 List THREE personal factors of a prospective entrepreneur that could influence the success of any new business. (3)
- 10.2 You are an entrepreneur. You have made an after-sales and tax profit of R18 903,00.
- You need to remunerate your three employees in the ratio of 1 : 2½ : 3½.
Your own remuneration is 40% of the profit.
- Calculate the amount each employee will receive. (5)

[8]**TOTAL: 100**

MECHANOTECHNOLOGY N3**FORMULA SHEET**

Any applicable formula may also be used.

1. *Design power = Power (electrical motor) × service factor*
2. *Corrected power per belt = (basic power per belt + power increment per belt) × correction factor*
3. *Belt length (L) = [(Pitch diameter of larger pulley + Pitch diameter of smaller pulley) × 1,57] + (2 × Centre Distance)*
4. *Force (F) = Pressure (P) × Area (A)*
5. *Work done (W) = Force (F) × Distance (s)*
6. *Volume (V) = Area of base (A) × Perpendicular height (⊥h)*

TABLE 1
SERVICE FACTORS FOR THE SELECTION OF WEDGE BELTS

TYPES OF DRIVEN MACHINES	TYPES OF PRIME MOVERS					
	'Soft' starts			'Heavy' starts		
	Hours per day duty			Hours per day duty		
	10 and under	Over 10 to 16	Over 16	10 and under	Over 10 to 16	Over 16
Class 1 – Light duty Blowers and fans Centrifugal compressors and pumps Belt conveyors (uniformly loaded)	1,0	1,1	1,2	1,1	1,2	1,3
Class 2 – Medium duty Blowers and fans Rotary compressors and pumps Belt conveyors (not uniformly loaded) Generators	1,1	1,2	1,3	1,2	1,3	1,4
Class 3 – Heavy duty Brick machinery Compressors and pumps (reciprocating) Conveyors (heavy duty) Hammer mills Punches and presses	1,2	1,3	1,4	1,4	1,5	1,6
Class 4 – Extra heavy duty Crushers Mills	1,3	1,4	1,5	1,5	1,6	1,8

TABLE 2

TABLE 2
CENTRE DISTANCES FOR 16 N-SPB WEDGE BELT DRIVES

Combined arc and belt length correction factor	0,8		0,85		0,9		1,05											
	1260	1340	1410	1590	1800	1900	2020	2150	2280	2400	4560	4820	5070	5380				
Speed ratio	Pitch diameter of pulleys		Power per belt kw		BELT LENGTH													
	Driver	Driven	960 r/min	1440 r/min														
1.69	236	400	11.94	16.56	-	-	-	392	443	504	570	635	696	1779	1909	2034	2189	
1.75	160	280	6.45	8.92	278	319	355	446	551	602	662	727	792	852	-	-	-	-
1.75	180	315	7.92	11.00	-	273	309	401	507	557	618	683	748	809	-	-	-	-
1.78	200	355	9.38	13.03	-	-	-	351	458	508	569	635	700	760	1843	1973	2098	-
1.79	140	250	4.95	6.80	319	360	395	486	591	641	702	767	832	892	-	-	-	-
1.79	224	400	11.10	15.41	-	-	-	400	452	513	578	644	705	1788	1918	2043	2198	